



2DM2280

Digital Stepper Drive

Manual



Amtech Ltd

TEL:- 0191 268 2022

www.Amtechltd.co.uk

Email :- Sales@amtechltd.co.uk

Address:- Samson Close, George Stephenson Ind Est

Killingworth, Newcastle upon tyne

NE12 6DX

Thanks for selecting Amtech stepper motor driver. We hope that the superior performance, outstanding quality, excellent cost performance of our product can help you accomplish your motion control project.

The content in this manual has been carefully prepared and is believed to be accurate, but no responsibility is assumed for inaccuracies.

Version	Editor	Verifier
V1.0	R&D	R&D

Contents

1. Overview	- 4 -
2. Features	- 4 -
3. Ports Introduction	- 5 -
3.1 Control Signal Input Ports	- 5 -
3.2 ALM signal output ports.....	- 5 -
3.3 Power Interface Ports.....	- 7 -
4. Technological Index	- 8 -
5. Connections to Control Signal	- 9 -
5.1 Connections to Common Anode.....	- 9 -
5.2 Connections to Common Cathode	- 10 -
5.3 Connections to Differential Signal	- 11 -
5.4 Connections to 232 Serial Communication Interface	- 12 -
5.5 Sequence Chart of Control Signals.....	- 12 -
6. DIP Switch Setting	- 13 -
6.1 Activate Edge Setting	- 13 -
6.2 Running Direction Setting	- 14 -
6.3 Micro steps Setting	- 14 -
7. Faults alarm and LED flicker frequency	- 15 -
8. Appearance and Installation Dimensions	- 17 -
9. Typical Connection	- 17 -
10. Parameter Setting	- 19 -
11. Processing Methods to Common Problems and Faults	- 24 -
11.1 Power on power light off	- 24 -
11.2 Power on red alarm light on.....	- 24 -
11.3 After input pulse signal but the motor not running.....	- 24 -

1. Overview

The 2DM2280 is a two phase digital stepper driver based on DSP. Its Micro step resolutions and output current are programmable. And it has advanced control algorithm, which can brings a unique level of system smoothness, provides optimum torque and mid-range instability. The control algorithm of Multi-Stepping can make stepper motor has smooth system performance. The control algorithm of torque compensation can improve the torque of motor in the high speed. The control algorithm of motor self-test and parameter auto-setup technology offers optimum responses with different motors and easy-to-use. The control algorithm of smoothness can enhance the acceleration and deceleration of motor. Its unique features make the 2DM2280 to be an ideal solution for applications.

2. Features

- ◆ Parameter auto-setup and motor self-test
- ◆ Multi-Stepping inside
- ◆ Small noise, low heating, smooth movement
- ◆ Torque compensation in high speed
- ◆ Variable current control technology, High current efficiency
- ◆ Accelerate and decelerate control inside, Great improvement in smoothness of starting or stopping the motor

- ◆ Support PUL/DIR and CW/CCW modes
- ◆ Storage the position of motor
- ◆ Optically isolated input and compatible with 5V or 24V
- ◆ User-defined micro steps
- ◆ Microstep resolutions and Output current programmable
- ◆ Over current, over voltage and low voltage protection
- ◆ Green light means running while red light means protection or off line

3. Ports Introduction

3.1 Control Signal Input Ports

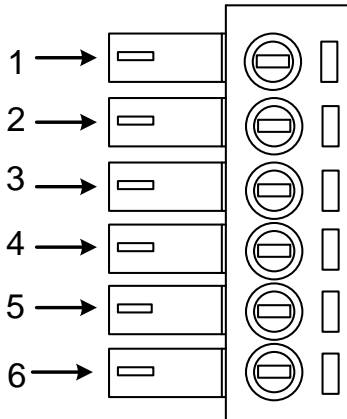

Port	Symbol	Name	Remark
1	DIR-	Direction signal-	Compatible with 5V or 24V
2	DIR+	Direction signal+	

3	PLS-	Pulse signal -	Compatible with 5V or 24V
4	PLS+	Pulse signal +	
5	ENA-	Enable signal -	Compatible with 5V or 24V
6	ENA+	Enable signal +	

3.2 ALM signal output ports

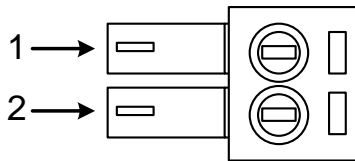

Port	Symbol	Name	Remark
1	ALM+	Alarm output +	
2	ALM-	Alarm output -	

3.3 Power Interface Ports

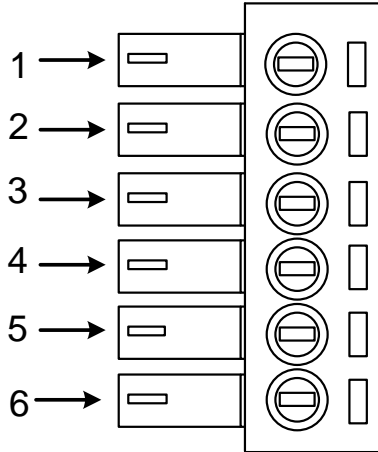

Port	Identification	Symbol	Name	Remark
1	Motor Phase Wire Input Ports	A+	Phase A+	Motor Phase A
2		A-	Phase A-	
3		B+	Phase B+	Motor Phase B
4		B-	Phase B-	
5	Power Input Ports	AC1	AC80V-240V	
6		AC2		

4. Technological Index

Input Voltage	80~240VAC	
Output Current	8A	
Pulse Frequency max	200K	
Communication rate	57.6Kbps	
Protection	<ul style="list-style-type: none">● Over current peak value 15A±10%● Over voltage value 350V● The over position error range can be set through the HISU	
Overall Dimensions (mm)	192×127×85	
Weight	Approximate 1500g	
Environment Specifications	Environment	Avoid dust, oil fog and corrosive gases
	Operating Temperature	+70°C Max
	Storage Temperature	-20°C ~+80°C
	Humidity	40~90%RH
	Cooling method	Natural cooling or forced air cooling

5. Connections to Control Signal

5.1 Connections to Common Anode

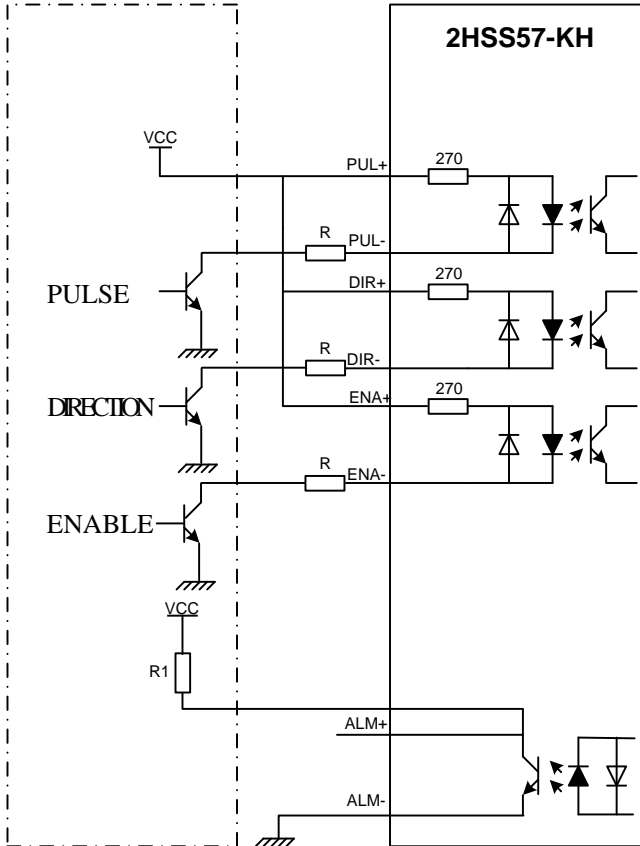

Remark:

VCC is compatible with 5V or 24V;

R(3~5K) must be connected to control signal terminal.

5.2 Connections to Common Cathode

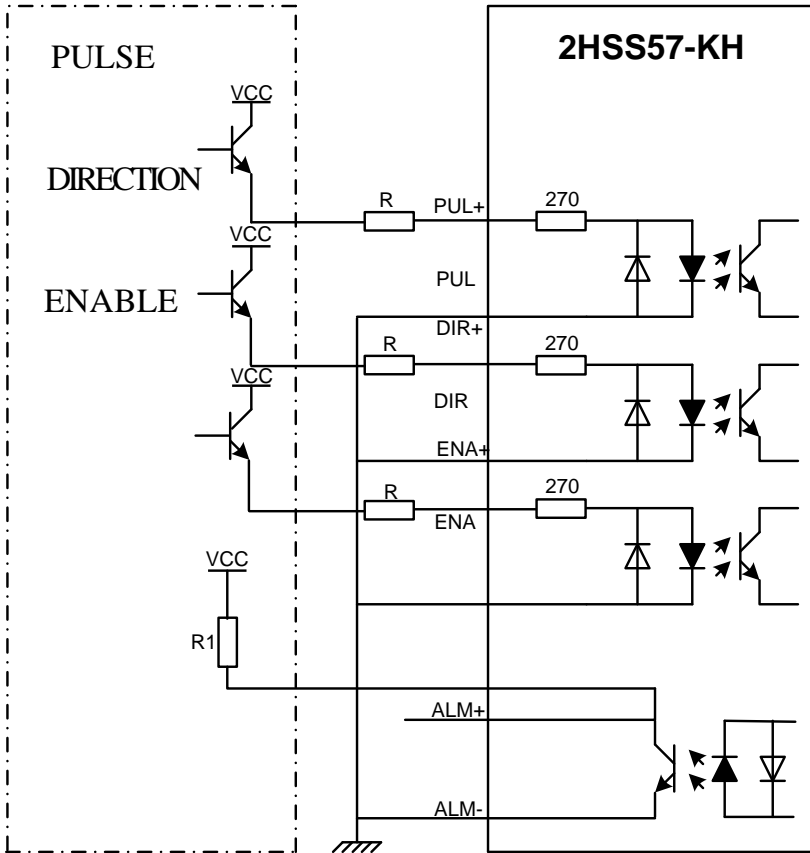

Remark:

VCC is compatible with 5V or 24V;

R(3~5K) must be connected to control signal terminal.

5.3 Connections to Differential Signal

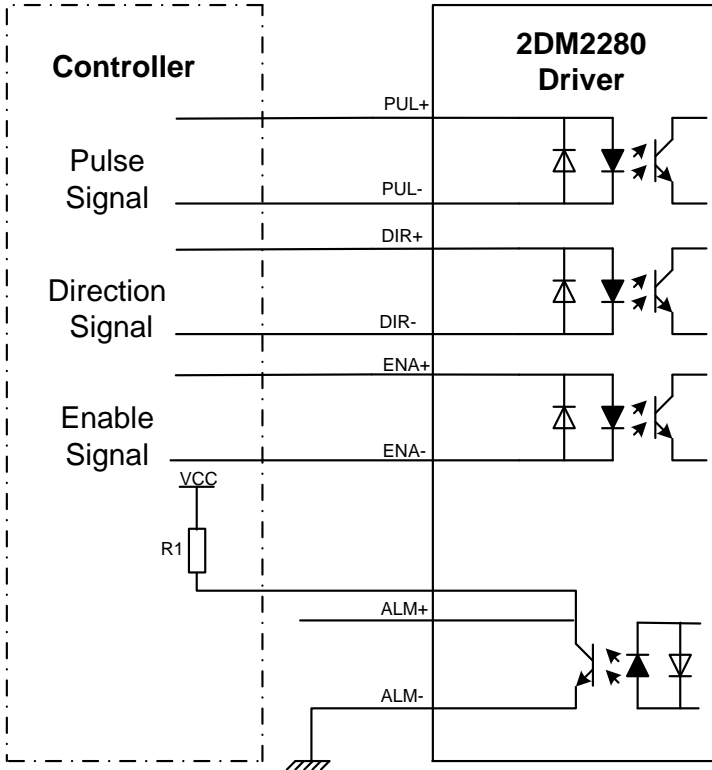

Remark:

VCC is compatible with 5V or 24V;

R(3~5K) must be connected to control signal terminal.

5.4 Connections to 232 Serial Communication Interface

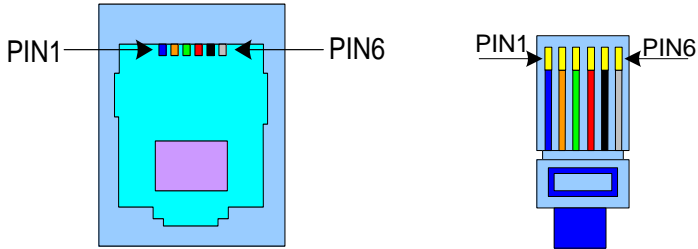

Crystal Head foot	Definition	Remark
1	TXD	Transmit Data
2	RXD	Receive Data
4	+5V	Power Supply to HISU
6	GND	Power Ground

5.5 Sequence Chart of Control Signals

In order to avoid some fault operations and deviations, PUL, DIR and ENA should abide by some rules, shown as following diagram:

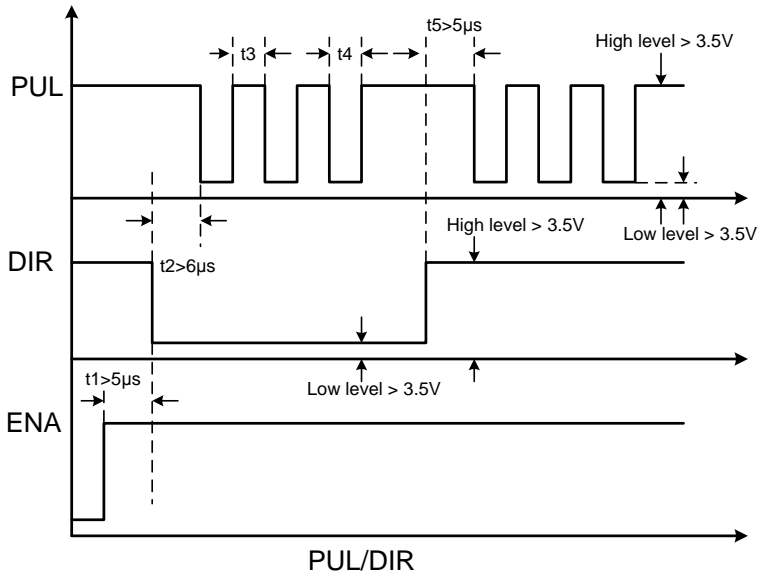

Remark:

- t_1 : ENA must be ahead of DIR by at least $5\mu\text{s}$. Usually, ENA+ and ENA- are NC (not connected).
- t_2 : DIR must be ahead of PUL active edge by $6\mu\text{s}$ to ensure correct direction;
- t_3 : Pulse width not less than $2.5\mu\text{s}$;
- t_4 : Low level width not less than $2.5\mu\text{s}$.

6. DIP Switch Setting

6.1 Current Setting

The current setting is in the following table.

Dial switch Current	SW1	SW2	SW3
Default	0	0	0
2. 2A	1	0	0
3. 2A	0	1	0
4. 5A	1	1	0
5. 2A	0	0	1
6. 3A	1	0	1
7. 2A	0	1	1
8. 2A	1	1	1

6.2 Standstill current Setting

SW4 is used for setting the standstill current , “off” means the standstill current is set to be half of the selected dynamic current or other current, which can be set by the Amtech HISU, the details can be seen in the tenth sections. while “on” means the standstill current is set to be the same as the selected dynamic current.

6.3 Micro steps Setting

The micro steps setting is in the following table. And the micro steps can be also setting through the Amtech HISU. The details can be seen in the tenth sections.

Dial switch Micro steps	SW5	SW6	SW7	SW8
Default	1	1	1	1
400	0	1	1	1
800	1	0	1	1
1600	0	0	1	1
3200	1	1	0	1
6400	0	1	0	1
12800	1	0	0	1
25600	0	0	0	1
1000	1	1	1	0
2000	0	1	1	0
4000	1	0	1	0
5000	0	0	1	0
8000	1	1	0	0
10000	0	1	0	0
20000	1	0	0	0
25000	0	0	0	0

7. Faults alarm and LED flicker frequency

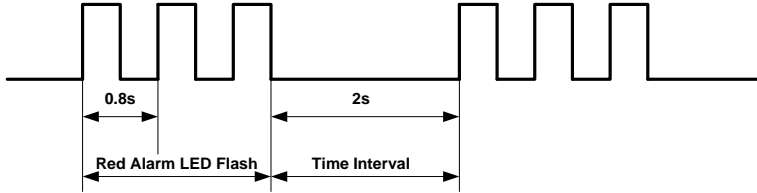

Flicker Frequency	Description to the Faults
1	Error occurs when the motor coil current exceeds the drive's current limit.
2	Voltage reference error in the drive
3	Parameters upload error in the drive
4	Error occurs when the input voltage exceeds the drive's voltage limit.

8. Appearance and Installation Dimensions

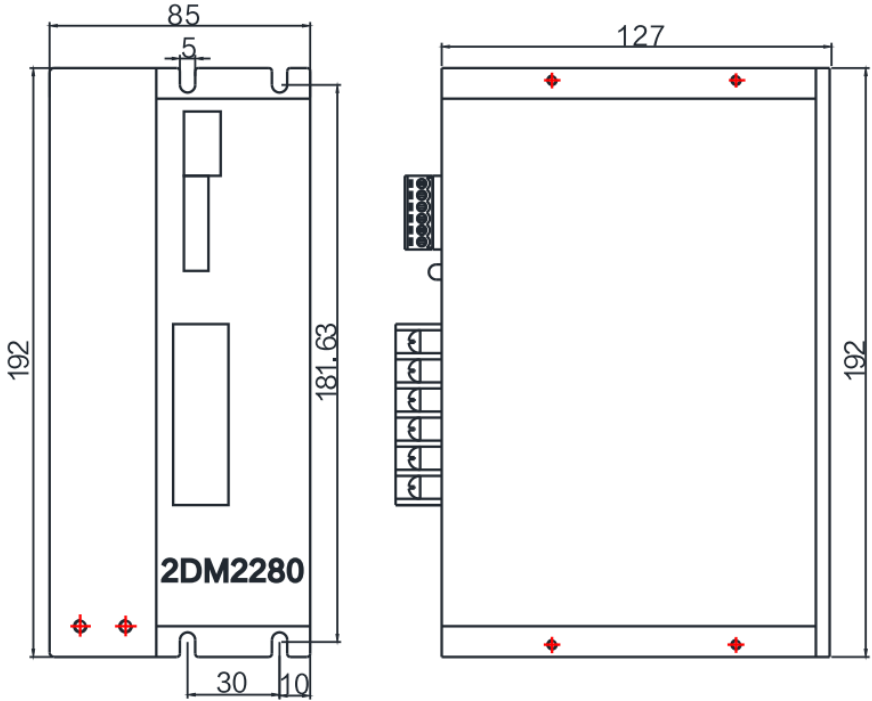

9. Typical Connection

Here is the typical connection of 2DM2280.

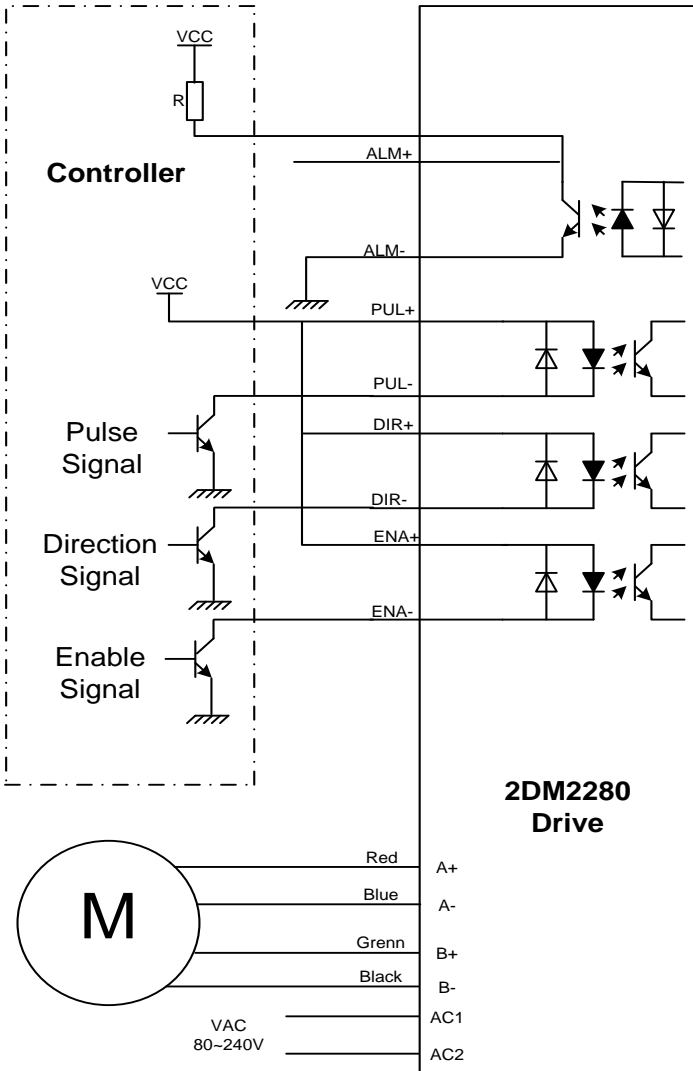

10. Parameter Setting

The parameter setting method of 2DM2280 drive is to use a Amtech HISU adjuster through the 232 serial communication ports, only in this way we can set the parameters we want. There are a set of best default parameters to the corresponding motor which are carefully adjusted by our engineers, users only need refer to the following table, specific condition and set the correct parameters.

Actual value = Set value × the corresponding dimension

Mode	Definition	Range	Dimension	Drive Restart	Default Value
P1	Current loop Kp	0—4000	1	Y	4000
P2	Current loop Ki	0—1000	1	Y	100
P3	Damping coefficient	0—500	1	N	100
P4	Amplitude of first resonance point	0—100	1	N	0
P5	Phase of first resonance point	0—100	1	N	0
P6	Amplitude of second resonance point	0—100	1	N	0
P7	Phase of second resonance point	0—100	1	N	0
P8	Amplitude of third resonance point	0—100	1	N	0
P9	Reserved				
P10	Enable signal level	0—1	1	N	1
P11	Reserved				

P12	Reserved				
P13	Command Type	0—1	1	N	0
P14	User-defined micro steps	4—1000	50	Y	0
P15	Time of standstill current	0—4000	1ms	Y	1000
P16	Percentage of standstill current	0—100	1	Y	50
P17	Speed smoothness	0—10	1	Y	0
P18	Enable of position memory	0—1	1	Y	0
P19	User-defined resistance of motor	0—100	mh	Y	0
P20	User-defined inductance of motor	0—100	0.1Ohm	Y	0
P21	Result of position memory	0—128	1		0
P22	Time of enable position memory	0—100	1s	Y	5

There are total 22 parameter configurations, use the Amtech HISU to download the configured parameters to the drive, the detail descriptions to every parameter configuration are as follows:

Item	Description
Current loop Kp	Increase Kp to make current rise fast. Proportional Gain determines the response of the drive to setting

	<p>command. Low Proportional Gain provides a stable system (doesn't oscillate), has low stiffness, and the current error, causing poor performances in tracking current setting command in each step. Too large proportional gain values will cause oscillations and unstable system.</p>
<p>Current loop Ki</p>	<p>Adjust Ki to reduce the steady error. Integral Gain helps the drive to overcome static current errors. A low or zero value for Integral Gain may have current errors at rest. Increasing the integral gain can reduce the error. If the Integral Gain is too large, the system may “hunt” (oscillate) around the desired position.</p>
<p>Damping coefficient</p>	<p>This parameter is used to change the damping coefficient in case of the desired operating state is under resonance frequency.</p>
<p>Amp 1—3</p>	<p>2DM2280 Driver provides robust anti-resonance control to stop the vibrations and maintain equilibrium.</p>
<p>Phase 1—3</p>	<p>Amp1 and Phase1 is Phase adjustment for 1st and Amplitude adjustment for 1st resonance area respectively. Usually between 0.6rps and 1.2rps. Amp2 and Phase2 is Phase adjustment for 2nd and</p>

<p>Enable Control</p>	<p>Amplitude adjustment for 2nd resonance area respectively. Usually between 1.2rps and 2.4rps. Amp3 and Phase3 is Phase adjustment for 3rd and Amplitude adjustment for 3rd resonance area respectively. Usually between 2.4rps and 4.8rps. This parameter is set to control the Enable input signal level, 0 means low, while 1 means high.</p>
<p>User-defined micro steps</p>	<p>This parameter is set of user-defined micro steps. The actual micro steps = the set value \times 50. For example, if the parameter is 4, the micro steps is $4 \times 50 = 800$. But If this parameter is 0, which means micro steps is set by the outer DIP switches.</p>
<p>Time of standstill current</p>	<p>This parameter is set the time when the standstill current is set to be half of the selected dynamic current or other current,</p>
<p>Percentage of standstill current</p>	<p>This parameter is set the percentage of standstill current.</p>
<p>Speed smoothness</p>	<p>This parameter is set to control the smoothness of the speed of the motor while acceleration or deceleration, the larger the value, the smoother the speed in acceleration or deceleration.</p>

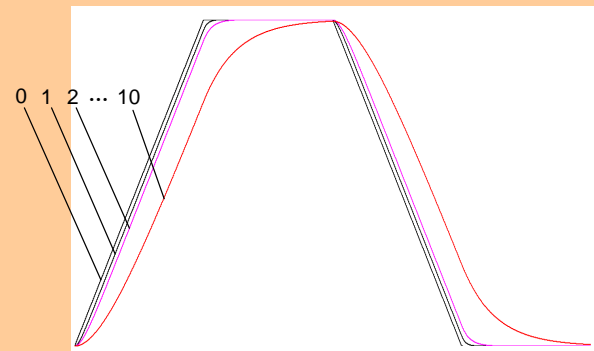
	
<p>Enable of position memory</p>	<p>This parameter is set to enable the function of position memory. 0 means disable, while 1 means enable. If set 1, the 2DM2280 can remember the position of motor in the next time of power on.</p>
<p>Command Type</p>	<p>This parameter is set to choice the PUL/DIR mode or CW/CCW mode. 0 means PUL/DIR mode, while means CW/CCW mode.</p>
<p>User-defined resistance of motor</p>	<p>This parameter is set the resistance of motor. 0 means 2DM2280 gets the resistance by control algorithm of Parameter auto-setup, while 1 means 2DM2280 gets the resistance through user sets.</p>
<p>User-defined inductance of motor</p>	<p>This parameter is set the inductance of motor. 0 means 2DM2280 gets the inductance by control algorithm of Parameter auto-setup, while 1 means 2DM2280 gets the inductance through user sets.</p>

Result of position memory	This parameter is set to control the smoothness of Display the result of position memory
Time of enable position memory	This parameter is set of the time when enable the position memory. The time is mean the space of time to stop plus input.

11. Processing Methods to Common Problems and Faults

11.1 Power on power light off

- No power input, please check the power supply circuit. The voltage is too low.

11.2 Power on red alarm light on

- Please check the motor is connected with the drive.
- The stepper digital drive is over voltage or under voltage. Please lower or increase the input voltage.

11.4 After input pulse signal but the motor not running

- Please check the input pulse signal wires are connected in reliable way.
- Please make sure the input pulse mode is corresponding with the real input mode.
- The Driver is disabled